

**128Mbps
HPNA3.0 over Coax
Ethernet Bridge**

CET-330

User's Guide

V2.0

M73-APO09-800

INTRODUCTION

This HCNA (HomePNA3.0 over Coax) to Ethernet bridge connects any Ethernet device to a high speed access device or to a LAN for Internet access. This bridge brings you the newest Ethernet compatible technology that uses the coaxial cable as the network's physical wiring thereby eliminating the need to install new wiring. It is designed to operate on the coaxial TV cable installed in homes.

This bridge allows you to connect PCs and Ethernet enabled devices, such as Switch, HUB and printers, to a Home Networking LAN by simply plugging into the existing coaxial F-Type connector.

Features

- Plug & Play
- Using existing coaxial TV cable to build a home network
- Shares high speed Internet access and streaming video
- 1 port 128Mbps connection compliant with HomePNA 3.0 over Coax (HCNA) standard
- 2 Standard 10/100BaseT Fast Ethernet ports for connecting to Ethernet or cable modem
- 10/100Mbps Auto Negotiation Support
- MDI/MDIX Auto Crossover Support
- QoS Priority Mapping Support

HARDWARE INSTALLATION

Parts Names and Functions

LED Indicators on the Front Panel

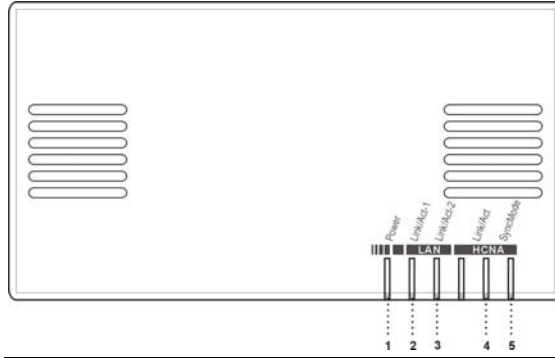



	LED	Status		
		Glowing	Dimming	Flashing
①	Power	Powered by DC5V	Not powered	N/A
②	LAN Link /Act	LAN 1 Link	Disconnect or Link fail	Receive or Transmit
③	LAN Link /Act	LAN 2 Link	Disconnect or Link fail	Receive or Transmit
④	HCNA Link /Act	HCNA Link	Disconnect or Link fail	Receive or Transmit
⑤	HCNA SyncMode	Sync. Mode	Async. Mode	N/A

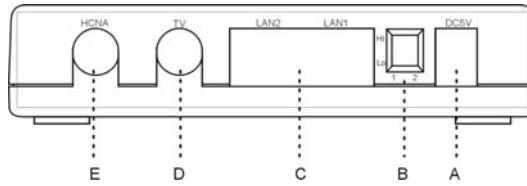

Ports on the Rear Panel

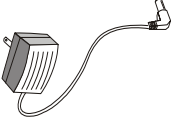

	Port Name	Type	Functions
A	DC5V	DC	Connect to the power adapter plug.
B	DIP Switch	DIP	Reserved
C	LAN1/LAN2 (Ethernet)	RJ-45	Connect to Ethernet port on FTTH or xDSL Modem or Switch for Internet Access.
D	TV	F	Connect to TV
E	HCNA	F	Connect to HCNA devices

Essential Hardwares

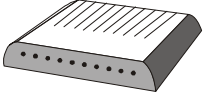
Items Included	Description	Purpose
	HCNA to Ethernet Bridge	Main Unit
	Coaxial Cable (F-Type/RG-59U)	Connects from HCNA port to coax F-Type connector on the wall outlet.
	CAT5 Ethernet cable	Connects from LAN port to Ethernet enabled devices as PC
	DC5V Power adapter	Connects from power port of the main unit into a wall outlet

Additional Items (Not included)	Description
	A well-installed WAN environment (FTTH or xDSL Modem)
	A well-installed LAN environment

Hardware Connections

1. Select a convenient location for the bridge near the PC or Ethernet device to which it will be connected. The bridge should be kept away from excessive heat.
2. Using one coaxial cable to connect the **HCNA** port to F-Type connector on the wall. Using another coaxial cable to connect the other F-type **TV** port to TV set.
3. Connect the **LAN1/LAN2** port to your Ethernet-equipped device.
4. Connect the power adapter to the **DC5V** port into a wall outlet.

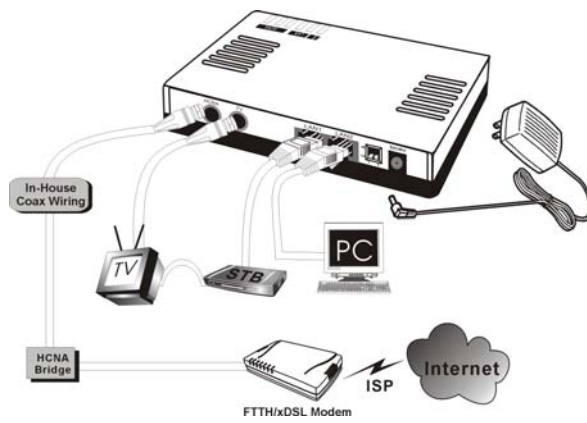

The figure above shows how to connect an xDSL modem to a home coaxial cable network. Follow the same steps to connect any Ethernet device such as a HUB or printer, to a coaxial cable network.

Now you should have connected the **LAN** port, **HCNA** port and the **DC5V** port to the appropriate devices or lines. LED will be as:

POWER	ON
LAN Link/Act	ON
HCNA Link/Act	ON
HCNA SyncMode	ON

For more information on LEDs, see section "LED Indicators on the Front Panel"

TROUBLESHOOTING

The bridge has been designed to be a reliable and easy to use connection device. Please refer to the list below to aid in troubleshooting.

The Power (green) LED is off.

- *Make sure the power adapter is properly plugged into a live electrical outlet.*

The LAN(Ethernet) or HCNA Link/Act LED is off.

- *Make sure the connection to these two ports is secure.*
- *The Ethernet or HCNA device to which you are connected should be powered on and properly configured.*

The HCNA SyncMode LED is off.

- *The LED should be always ON after power on.*
- *The Ethernet or HCNA device to which you are connected should be powered on and properly configured.*

SPECIFICATIONS

Standards

- IEEE 802.3 10BaseT Ethernet compliant
- IEEE 802.3u 100BaseT Fast Ethernet compliant
- HomePNA 3.0 over Coax (HCNA) compliant

Data Rates

- HCNA: 128 Mbps
- Ethernet: 10/100 Mbps

Distances

- HCNA : 1200 meter maximum between the two farthest nodes on LAN
- Ethernet: 100 meter maximum

Power Consumption:

- 5V DC IN, Less than 4 watt

Certifications

- CE, FCC Part 15

LEDs

- Power
- Ethernet Link/Activity
- HCNA Link/Activity; SyncMode

Connectors

- Two F-Type connectors, one for connecting with HCNA device, and one for TV
- Two RJ-45 for 10/100M Ethernet

Cables

- HCNA Network: F-Type RG-59U coaxial cable
- Fast Ethernet: CAT5 or better UTP